



Mercer Island Arts Council Regular Meeting

Agenda | August 14, 2019

Mercer Island Community & Event Center
8236 SE 24th St., Mercer Island, WA 98040

6:30 PM CALL TO ORDER

6:30 PM APPEARANCES

6:35 PM APPROVAL OF MINUTES

Regular Meeting Minutes, July 10, 2019

6:40 PM 2019 BUDGET REPORT, Sarah Bluvus

6:45 PM FUNDING REQUEST: SeaJAM Festival, Pamela Lavitt, SJCC

7:00 PM COMMUNITY ENGAGEMENT OPPORTUNITIES, ALL

Discussion: Community survey and website updates

Discussion: Community engagement ideas for Farmer's Market and Art Uncorked

Action Requested: Volunteer at Farmer's Market and Art Uncorked

7:40 PM PROJECT PROPOSALS RUBRIC AND BYLAWS REVIEW, All

Discussion: Updates to Rubric to Evaluate Project Proposals

Discussion: Second review of proposed amendments to Bylaws

Action Requested: Adopt proposed amendments to Bylaws

8:00 PM PROGRAM & LIAISON REPORTS

Chair Report/Public Art, Erin Vivion

Gallery, Amy Barnes

Update: Aubrey Davis Park master plan

Update: *Blomstre* installation for Greta Hackett Outdoor Sculpture Gallery

Action Requested: Volunteer to assist with gallery install on Saturday, September 7

Literary, Erik Gordon

Master Plan (ad-hoc committee), Amy Barnes and Erik Gordon

Mostly Music in the Park, Matt Lome

Community Relations, Damian Schwiethale

FAAC, Alice Finch

MIVAL, Claudia Zimmerman

8:25 PM STAFF UPDATES, Sarah Bluvus and Diane Mortenson

8:30 PM ADJOURN

Arts Council Members

- 1 Anumeha
- 2 Suzanne Skone
- 3 Gaylene Vaden
- 4 Amy Barnes, Vice Chair
- 5 Matt Lome
- 6 Erin Vivion, Chair
- 7 Erik Gordon
- 8 Damian Schwiethale
- 9 Xixi Shakes

City Council Liaison

Salim Nice

Staff

Sarah Bluvus

Diane Mortenson

MIVAL Liaison

Claudia Zimmerman

FAAC Liaison

Alice Finch

Next Meeting: September 11, 2019

2019 Arts Council Group Norms/Guiding Principles
Adopted at the Arts Council Retreat – 03.02.19

Everyone contributes.

- Listen actively.
- Create a space in which all members feel comfortable speaking up.
- Encourage respectful debate.

Foster a collaborative environment.

- Work better together.
- Stay open to new ideas and ways of thinking.
- Seasoned members mentor new members.
- Once a decision is made, everyone commits to that decision.

Hold each other accountable.

- Evaluate projects and ideas equally.
- Focus on the group's goals.
- Identify and leverage the skills everyone brings to the table.

Get to know each other and the community.

- Socialize with each other.
- Expand the network by bringing friends, neighbors, etc., along – create a pipeline/succession plan.

Be transparent and accessible.

- Check for understanding by paraphrasing.
- Foster open communication.



ARTS COUNCIL MINUTES

JULY 10, 2019

Call to Order

The meeting was called to order by Chair Erin Vivion at 6:34 pm at Mercer Island Community & Event Center, 8236 SE 24th Street, Mercer Island, WA 98040.

Roll Call

- Members Present: Anumeha, Amy Barnes, Erik Gordon, Damian Schwiethale, Xixi Shakes, Suzanne Skone, and Erin Vivion
- Members Absent: Matt Lome and Gaylene Vaden
- City Council: Deputy Mayor Salim Nice absent
- Staff: Sarah Bluvus and Diane Mortenson
- Guests: Louise Hanks, local artist

Appearances

No appearances.

Minutes

It was moved by Skone; seconded by Gordon to:

Approve the June 12, 2019, as presented.

Passed 7-0

FOR: 7 (Anumeha, Barnes, Gordon, Schwiethale, Shakes, Skone, Vivion)

AGAINST: 0

ABSENT: 2 (Lome, Vaden)

2019 Budget Report – Sarah Bluvus

Bluvus reported that \$13,701.68 remains in the Arts Council's 2019 operational budget.

Summer Events Schedule – Sarah Bluvus

Bluvus reminded the board about the schedules for Mostly Music in the Park and Shakespeare in the Park. She requested volunteers to welcome audiences at MMIP on July 25 and August 15 and at Shakespeare in the Park at a performance of each play. Members should follow up with her if they are able to participate.

Bylaws and Community Arts Support Rubric Review – All

Community Arts Support Rubric: The board reviewed a draft of a rubric to evaluate external and internal project/program proposals. Members suggested renaming the rubric and the scale to determine community readiness.

It was moved by Barnes; seconded by Schwiethale to:

Adopt the project proposal rubric with discussed changes to title and scoring nomenclature.

Passed 6-0-1

FOR: 6 (Anumeha, Barnes, Gordon, Schwiethale, Shakes, Vivion)

AGAINST: 0

ABSTAIN: 1 (Skone)

ABSENT: 2 (Lome, Vaden)

Bylaws Update: The board discussed proposed amendments to the Arts Council Bylaws. Bluvas will update the draft based on discussion and bring to the next Regular Arts Council Meeting for the second review.

Aubrey Davis Park Cultural Arts/Placemaking Visioning Check-In – All

The board discussed needs and concerns related to the cultural arts/placemaking visioning process for the Aubrey Davis Park master plan. They decided to establish an ad-hoc committee to work closely with staff on the remaining work and to develop a plan for how best to engage the full board moving forward. Bluvas will follow up to identify volunteers to serve on the committee and set a meeting date before the next Regular Arts Council Meeting. The board will also tour Aubrey Davis Park on Wednesday, July 24, with Paul West.

For the sake of time, Chair Vivion asked to address the remaining agenda topics briefly or via committee. The board accepted this request.

Discussion of *Blomstre* by Louise Hanks – All

Barnes and Louise Hanks presented their request to display *Blomstre*, a new sculpture by Hanks, for sale in the Greta Hackett Outdoor Sculpture Gallery.

It was moved by Schwiethale; seconded by Skone to:

Display *Blomstre* by Louise Hanks for sale in the Greta Hackett Outdoor Sculpture Gallery, pending the feasibility of installation as determined by City staff, the Gallery Committee Chair, and the artist.

Passed 6-0-1

FOR: 6 (Anumeha, Gordon, Schwiethale, Shakes, Skone, Vivion)

AGAINST: 0

ABSTAIN: 1 (Barnes)

ABSENT: 2 (Lome, Vaden)

Update on *Handsome Bollards* Restoration – Sarah Bluvas

Peter Kopetzky estimates the *Handsome Bollards* restoration will cost \$6,400 (+tax). Bluvas requested the board's approval to use funds from the public art maintenance line-item (PRAT40) in the 1% for Art in Public Places fund to complete the restoration.

After amendment, it was moved by Vivion; seconded by Anumeha to:

Approve the request to use funds from the public art maintenance line-item (PRAT40) in the 1% for Art in Public Places fund to work with Peter Kopetzky to restore the *Handsome Bollards* installation, provided that the final cost does not exceed the estimate of \$6,400 (+tax).

Passed 6-1

FOR: 6 (Anumeha, Barnes, Gordon, Schwiethale, Shakes, Vivion)

AGAINST: 1 (Skone)

ABSENT: 2 (Lome, Vaden)

Program Reports – All

Community Relations: Schwiethale requested that the board review the survey questions he sent out via e-mail on July 11. He will follow up with individuals to meet in committee about community engagement opportunities at the Farmer's Market and Art Uncorked.

Adjournment

Chair Vivion adjourned the meeting at 8:57 pm.

Mercer Island Arts Council - 2019 Operating Budget *(Budget to Actual - As of 08.12.19)*

Expense Area	2019 Budgeted	2019 Actual	2019 Pending	Additions
PR5200: Public Art				
Operating supplies (placards, signage, etc.)	\$ 800.00	\$ -	\$ -	\$ -
PR5300: Community Arts Support				
Arts Council Swing Dance (VFW Hall rental, supplies, etc.)	\$ 1,600.00	\$ -	\$ -	\$ -
Dance for PD	\$ 750.00	\$ 750.00	\$ -	\$ -
PR5400: Gallery				
Operating supplies (reception food, etc.)	\$ 1,200.00	\$ 367.15	\$ 150.58	\$ -
Professional services (outdoor gallery installation stipend)	\$ 1,400.00	\$ -	\$ -	\$ -
Musicians at receptions	\$ 1,500.00	\$ 700.00	\$ 200.00	\$ -
Marketing and promotion (advertising, printing, etc.)	\$ 1,400.00	\$ -	\$ -	\$ -
PR5500: Literary Program				
Classics on Film honoraria (Lance Rhodes)	\$ 3,000.00	\$ 1,200.00	\$ 800.00	\$ -
Meet the Author event	\$ 400.00	\$ -	\$ -	\$ -
Marketing and promotion (advertising, printing, etc.)	\$ 450.00	\$ -	\$ -	\$ -
PR5600: Cultural & Performing Arts				
Event supplies	\$ 100.00	\$ -	\$ 16.53	\$ -
Mostly Music in the Park sound engineering	\$ 5,200.00	\$ -	\$ 6,784.80	\$ -
Mostly Music in the Park bands	\$ 7,000.00	\$ 6,000.00	\$ 1,000.00	\$ -
Shakespeare in the Park performances	\$ 7,000.00	\$ -	\$ 7,000.00	\$ -
Marketing and promotion (poster design/distribution, banners, etc.)	\$ 2,920.00	\$ 260.00	\$ 1,600.40	\$ -
PR5700: Special Programs				
Operating supplies (office supplies, retreat supplies, etc.)	\$ 500.00	\$ 274.43	\$ -	\$ -
Dues and subscriptions (STQRY, professional networks, etc.)	\$ 3,000.00	\$ 1,235.53	\$ -	\$ -
Marketing and promotion (Arts Council branding)	\$ 750.00	\$ -	\$ -	\$ -
Miscellaneous grants and sponsorships	\$ 2,000.00	\$ -	\$ -	\$ -
TOTAL	\$ 40,970.00	\$ 10,787.11	\$ 17,552.31	\$ -
<i>Remaining</i>	<i>\$</i>			<i>12,630.58</i>

1% for Art in Public Places Fund Balance

Cash Balance as of 01.01.19	\$ 143,011.81
2018 - Contributions	
Contributions	\$ 30,222.00
2018 Town Center Banners	\$ (300.00)
Net 2018 contributions	\$ 29,922.00
2019 Budget - Commitments or Future Use of Cash	
Anticipated Contributions	\$ 10,000.00
Annual art maintenance (2018)	\$ (15,000.00)
Net 2019 contributions (est.)	\$ (5,000.00)
<i>Est. Cash Available at year's end (12.31.19)</i>	<i>\$ 167,933.81</i>



SeaJAM 2019? September 13 – 15, 2019 – Celebrating the Stroum JCC’s 50th Anniversary on Mercer Island!

SeaJAM, now in its second year, is a new festival celebrating Jewish life, art, and culture and features up-and-coming performers and top acts in music and comedy as well as family shows. This cornerstone program of the SJCC’s Arts + Ideas season brings rarely seen Jewish and Israeli talent to the Pacific Northwest to engage, educate, and inspire the Jewish and wider communities. “We are very excited about this year’s lineup at our second annual SeaJAM,” said SJCC CEO Amy Lavin. “It will bring excitement, delight and, most importantly, community celebration to this milestone year in which we are celebrating our 50th year on Mercer Island and 70th in greater Seattle. The SJCC remains a place where friendships form, traditions thrive and community strengthens, and in this anniversary year, we recommit to creating experiences that unify us, celebrate Jewish values and ensure that we all feel connected in and around the SJCC. This year’s SeaJAM lineup does just that.” Everyone can get their “JAM” on at our region’s only Jewish Music + Art Festival.

Overview of last year’s event success (total audiences, funds raised, etc.)

- Total Audience: 750 in two days | Family rock concert sold out
- Funds raised: \$43,500 in contributed income/sponsorship | \$8,000 in earned income via ticket sales
- For a first festival, we were pleased with fundraising, community support, and attendance for all but the dance event. In addition to the date change, we decided that curating in areas we have engaged and dedicated audience would be the focus moving forward: concerts, author/celebrity/chef talks, food events, exhibits, and family shows. This is what we are best equipped to produce in our theater and garner targeted and engaged audiences for.

Details of this year’s lineup and intended audience for this year’s event (local, regional, etc.)

- **Challah bake off:** local community bakers’ judge lay baker’s best braided bread. Judges include Shawn of Shawn’s Bakery on Mercer Island, Hello Robin Bakery, and Shwartz Brother’s Bakery. Free. \$18 to enter contest.
- **Debra Messing** (moderated by Kim Holcomb, “Evening Magazine”): TV/theatre/film audience; GLBTQ audiences; women; celebrity event fans; Jewish community
- **Joel Gamoran:** cooking show and cookbook audience; foodies; JCC families and supporters; Mercer Island families; restaurateurs and food entrepreneurs.
- **The Maccabeats:** music lovers of all ages; Jewish community; kids and families

Details about this year’s planning and execution (marketing plan/timeline, other sponsors, etc.)

- This is a very complicated question. I am more than happy to share our marketing timeline but it is over 2 pages long with day to day emails, blasts, advertising, social media posts and printed collateral
- I will bring printed materials to the meeting and a rundown of this to go over. It’s more detail than people need
- Paid media: KUOW, Stranger, Seattle Times, social media, ParentMap
- Sponsors to date:

- Engelstein Family
- Lott Family
- Sharon Gantz Bloome Fund of the Tides Foundation
- Aegis Living (of Mercer Island)
- Island House
- Mary Lee Real Estate (Mercer Island)

Any other details that set SeaJAM apart (Island demand for this program, creative quality/diversity in performers/art forms, etc.)

- Change of date:
 - We moved the festival from December to September to kick off our season
 - We moved the festival to September to celebrate the JCC's 50th anniversary on Mercer Island closer to the end of our fiscal year
 - We moved the festival to September to avoid considerable holiday conflicts experienced last year in terms of community, arts, and family calendaring, and to avoid Hanukkah and Christmas performances and popular community events and overload
- Shift in curatorial focus:
 - Headliners with known following and more recognizable to the general public
 - Community and family oriented
 - Celebrate the JCC's 50th anniversary and our "All Love, No Lonely" mission to bring people together and spark joy in experiencing connection and culture through the arts. Joel Gamoran in particular embodies the story of a child who grew up in part on mercer Island and at the JCC, and food embodies an important Jewish value of "not wasting" and care for the environment and has a connection to our Keshet Community Garden, where everyone is welcome
 - Expand beyond our theatre, if larger venue needed (i.e., Benaroya Hall for Messing)

Mercer Island Arts Council Survey
DRAFT – As of 08.12.19

Opening

The Mercer Island Arts Council is evaluating current programming and initiatives, and we want to hear from YOU! Our goal is to capture feedback to help us in our upcoming budget process. With limited resources, we want to make sure our work continues to provide impact and value to Mercer Island citizens.

This anonymous survey is brief (<7 minutes) and open to all Islanders. The results will inform our 2021-2022 budget process, which will kick off in January 2020.

This survey is also available in print form. Download a copy here, or pick one up at the Mercer Island Gallery in the Mercer Island Community and Event Center. You can drop completed surveys off at the Mercer Island Gallery or mail them to:

Mercer Island Arts Council
c/o Sarah Bluvas
2040 84th Ave SE
Mercer Island, WA 98040

We appreciate your time and input!

Q1. Do you live on Mercer Island?

- Yes
 - No
-

General Questions

The questions in this section intend to gauge your general awareness and opinions of the Mercer Island Arts Council, its mission, and its goals.

Q2. Are you aware of the Mercer Island Arts Council?

- Yes
- No
- I'm not sure

Established in 1985, the Mercer Island Arts Council is a 9-member volunteer commission that advises the Mercer Island City Council on matters related to arts and culture. Committees of the Arts Council, working with the support of Parks and Recreation staff, provide community activities such as art gallery exhibits, outdoor concerts and plays, and literary events. The Arts Council also works with the Parks and Recreation department to steward the City's public art collection.

Q3. The Arts Council's mission is to **nurture, promote, and support high-quality cultural arts activities for the community.**

I believe this mission brings value to Mercer Island citizens and enhances arts and culture in the community.

- Strongly Agree
- Agree
- Neither agree nor disagree
- Disagree
- Strongly Disagree

Q4. The Arts Council's goals are to:

- Advocate for the arts, artists, and arts organizations of Mercer Island.
- Stimulate community awareness and enjoyment of the fine arts.
- Promote community education, awareness, and enjoyment of the arts.
- Support performing, visual, and literary arts programs, projects, and events.

I believe these goals bring value to Mercer Island citizens and enhance the arts in the community.

- Strongly Agree
- Agree
- Neither agree nor disagree
- Disagree
- Strongly Disagree

Arts Council Programs & Events

The following questions ask about your awareness and opinions of the programs and events offered by the Mercer Island Arts Council.

Q5. Are you aware of the following Arts Council programs and events? (Check all that apply.)

- Mostly Music in the Park
- Shakespeare in the Park
- Mercer Island Gallery
- Friday Night Films (formerly Classics on Film)
- Community Dances
- Dance for Parkinson's
- Meet the Author events
- Other (please specify)
- I am not familiar with these programs/events.

Q6. Have you attended any of the following Arts Council programs or events in the last year? (Check all that apply.)

- Mostly Music in the Park
- Shakespeare in the Park
- Mercer Island Gallery
- Friday Night Films (formerly Classics on Film)
- Community Dances
- Dance for Parkinson's
- Meet the Author

- Other (please specify)
- I have not attended any of these programs/events in the last year.

Q7. For each program/event listed in the matrix below, please answer with the degree to which you agree with the following statement:

This Arts Council program or event brings value to community members and enhances the arts environment on Mercer Island.

	Strongly Agree	Agree	Neither agree nor disagree	Disagree	Strongly Disagree
Mostly Music in the Park					
Shakespeare in the Park					
Mercer Island Gallery					
Friday Night Films					
Community Dances					
Dance for Parkinson's					
Meet the Author					

Q8. My favorite Arts Council program/event is: (Check up to three)

- Mostly Music in the Park
- Shakespeare in the Park
- Mercer Island Gallery
- Friday Night Films (formerly Classics on Film)
- Community Dances
- Dance for Parkinson's
- Meet the Author
- Other (please specify)
- None of the above.

Q9. With limited resources, we want to make sure our programs and events continue to provide impact and value for the community.

The Arts Council should retire this program/event in order to consider strengthening another program or implementing something new:

- Mostly Music in the Park
- Shakespeare in the Park
- Mercer Island Gallery

- Friday Night Films (formerly Classics on Film)
- Community Dances
- Dance for Parkinson's
- Meet the Author
- Other (please specify)
- None of the above.

Q10. Are there other programs or events that you would like the Arts Council to provide to the community?

Comment box

Public Art

The following questions ask about your awareness and opinions of the Arts Council's work to showcase and enhance the Mercer Island public art collection.

Q11. Are you aware that Mercer Island has a public art collection?

- Yes
- No
- I'm not sure

The Arts Council collaborates with artists, City staff, and the public to acquire high quality works that will enrich the lives of Islanders and preserve notable creative expression. Much of the collection has been purchased through the Mercer Island's "1% for Art in Public Places" fund, which is funding set aside from public construction projects, as well as through public donations.

Q12. Are you aware that the public art program has a dedicated fund called "1% for Art in Public Places" to support public art acquisitions, conservation, and maintenance?

- Yes
- No
- I'm not sure

Much of the City's public art collection has been funded via the 1% for Art in Public Places Fund (Municipal Code 4.40.200), which consists of funds set aside from capital improvement projects (CIP) to support public art acquisitions. Recent projects acquired with this fund include the mural on West Mercer Way, the mosaic murals at Luther Burbank Park playground, and the dragon play structure at Deane's Children's Park. Many works of art have also been donated to the collection, such as Stan, the bronze dog sculpture near the entrance to the dog park at Luther Burbank Park.

Q13. Are you aware of the public art acquisition process?

- Yes
- No
- I'm not sure

In 1992, the Arts Council adopted guidelines for acquiring new works of art via the 1% for Art in Public Places Fund.

Q14. The Arts Council should focus on considering new public art projects using 1% for Art in Public Places funding.

- Strongly Agree
- Agree
- Neither agree nor disagree
- Disagree
- Strongly Disagree

Q15. The Arts Council should incorporate more community input in the public art process.

- Strongly Agree
 - Agree
 - Neither agree nor disagree
 - Disagree
 - Strongly Disagree
-

Final Thoughts

The last few questions intent to gauge your overall opinion of the Arts Council and its work.

Q16. The Mercer Island Arts Council is an important commission of citizen volunteers that enables and cultivates an arts environment on the Island.

- Strongly Agree
- Agree
- Neither agree nor disagree
- Disagree
- Strongly Disagree

Q17. Within its limited resources, the Arts Council should consider pursuing more projects and initiatives to support arts and culture on Mercer Island.

- Strongly Agree
- Agree
- Neither agree nor disagree
- Disagree
- Strongly Disagree

Q18. Enriching communities with the arts has a strong economic and social impact on local businesses and residents.

- Strongly Agree
 - Agree
 - Neither agree nor disagree
 - Disagree
 - Strongly Disagree
-

Thanks for your time! Stay connected to the Mercer Island Arts Council by signing up to receive our e-newsletter.

Sign me up to learn more about upcoming Arts Council programs and events.

Name:

E-mail Address:

**Mercer Island Arts Council
Rubric to Evaluate Project Proposals**

Project Proposal:

Summary of Proposed Investment:

Directions: Enter numerical value in each scoring cell and add figures for total score

Criteria for Granting Project Support		Strength in Meeting Criteria (0-5)	Notes	Subtotal
Community Participation & Benefit	Considerations			
	<i>Will the proposed project enhance quality of life on Mercer Island?</i>			
	<i>Does the proposed project support local artists and/or arts, culture, and heritage organizations?</i>			
	<i>Will the proposed project appeal to a broad community audience?</i>			
Creative Quality & Diversity	Considerations			
	<i>Does the proposed project provide accessible, high-quality performing, visual, literary, and/or other arts and creative opportunities?</i>			
	<i>Does the proposed project highlight a new or unique concept or medium?</i>			
	<i>Does the proposed project include diverse voices and perspectives?</i>			
Demand for Services	Considerations			
	<i>Does the proposal demonstrate community need or demand for this project?</i>			
	<i>Does the applicant request start-up funding for a new or emerging project?</i>			
Planning & Execution	Considerations			
	<i>Does the applicant demonstrate past capability or success in producing this or similar projects?</i>			
	<i>Does the applicant have a well-developed project plan and a strategy for marketing & promotion?</i>			
	<i>Does the applicant demonstrate other matching funds?</i>			
	<i>Is the proposed budget realistic?</i>			
	<i>Does the applicant plan to collaborate with other individuals and/or organizations to execute the proposed project?</i>			
	<i>Does the applicant have a plan if the Arts Council cannot provide financial assistance?</i>			

Total Score

Assumptions:

> Criteria are weighted equally

> Considerations leveraged to better define value proposition of the proposal

> Score of (0-4) should not be pursued/supported

> Score of (5-10) should be prioritized for development/supported

> Score of (10+) should be developed/supported

CITY OF MERCER ISLAND MERCER ISLAND ARTS COUNCIL

BYLAWS

DRAFT as of 08.01.19

Items **highlighted in yellow** have been added/edited based on discussion at 07.10.19 Arts Council Meeting

The Mercer Island Arts Council ("Arts Council") is an advisory board to the Mercer Island City Council ("City Council") as established by Ordinances No. A-40 and A-41, passed by the City Council August 12, 1985, and codified as MICC 3.55, and 4.40.200. These bylaws constitute a supplement to said documents, providing further statements of the organization, procedures, activities, and objectives of the Arts Council. In any instance in which these bylaws might be interpreted to be contrary to said documents, the latter shall govern.

ARTICLE I – MISSION STATEMENT AND GOALS

The Arts Council's mission is to nurture, promote, and support quality cultural arts activities for the community of Mercer Island.

The Arts Council goals are to:

- Advocate for the arts, artists, and arts organizations of Mercer Island.
- Stimulate and promote community awareness, education, and enjoyment of the arts.
- Support performing, visual, literary, and other arts programs, projects, and events.

Commented [SB1]: Condensed second and third goals to eliminate redundancy.

ARTICLE II – DUTIES & RESPONSIBILITIES

The Arts Council's purpose is to advise and make recommendations to the City Council and other boards and commissions on matters related to arts and culture on Mercer Island. As an advisory board, the Arts Council recommends policies related to arts and culture, allocates funding from the Arts Council operating budget, and proposes arts and culture projects and initiatives. All recommendations are subject to City Council approval and staff capacity.

The Arts Council's duties and responsibilities are to:

- Develop the arts and culture plan as a component of Mercer Island's comprehensive plan and provide recommendations on periodic updates to the plan as directed by City Council.
- Provide a forum for the community to express their views on arts and culture and serve as a central body to promote, develop, stimulate, and encourage arts organizations, artists, and arts participation in Mercer Island.
- Establish guidelines for and advise Mercer Island's Design Commission on the commissioning, selection, and placement of permanent or temporary works of art in Mercer Island.
- Review the suitability and advise on the acceptance of art works intended as gifts to the city of Mercer Island.

Commented [SB2]: Follow-up: Planning and Design Commission bylaws do NOT reference public art in any capacity (FYI both commission's bylaws are much less detailed in terms of duties/responsibilities than this document)

- Participate in the selection of artists and performers for programs and events sponsored by the Arts Council.
- Support and foster an inclusive arts community that embraces the cultural diversity of its citizens and recognizes their contributions to the cultural landscape, including honoring and featuring local artists.
- Explore opportunities to obtain private, local, state, and/or federal funds to promote arts and cultural opportunities in Mercer Island.
- Facilitate communication and cooperation with existing organizations including schools, businesses, nonprofits, art organizations, foundations, and other community groups to bring artists and audiences together.
- Advise on other matters as directed by City Council.

ARTICLE III – ORGANIZATION

1. MEMBERSHIP

The Arts Council consists of nine persons recommended by the Mayor and Deputy Mayor and subject to appointment by the City Council. Members serve a term of four years and may serve no more than two consecutive terms. Each member's term shall expire on the last day of May.

2. OFFICERS

The elected officers of the Arts Council shall consist of a Chair and Vice Chair. The term of office for Chair and Vice Chair is one year. Each officer may serve a maximum of two consecutive terms.

Officer terms take effect beginning with the regular January meeting, and the election cycle is repeated annually.

If the Chair or Vice Chair vacates the position, the Arts Council will nominate and vote for a current member to fill the position at the Arts Council's next regular meeting.

Election Process

At the Arts Council's December meeting, the following process is conducted to elect new officer positions:

- Place motion to elect Chair and Vice Chair on the agenda.
- Take nominations for the position of Chair from the floor.
- Nominations do not require a second vote.
- If no further nominations, the Chair declares nominations closed.
- Voting takes place in the order nominations are made.
- If there is only one nomination, board members will vote on that nomination by a voice vote.
- If there is more than one nomination, each will be voted on separately by a roll-call vote of the members present.

- Once a nominee receives a simple majority vote, the nominee is declared elected to the position.
- If none of the nominees receive a majority vote, nominations are requested again, and the process is repeated until a candidate receives a majority vote.
- The process is repeated for Vice Chair.

Officer Duties

- Facilitate Arts Council meetings in a fair, efficient, productive, and informative manner.
- Act as the primary Arts Council representatives to City Council.
- Serve as the primary line of communication to City staff.
- Work with City staff to schedule meetings and develop meeting agendas.
- Appoint committee chairs.
- The Vice Chair attends meetings with staff and the Chair and fulfills duties of the Chair in the Chair’s absence.

3. COMMITTEES

The Arts Council includes six standing committees, and special or ad-hoc committees may be created as-needed. Committees are chaired by board members appointed by the officers, and committee members may be Arts Council members or other appropriate volunteers. Due to the requirements of the Open Public Meetings Act (Chapter 42.30 RCW), a committee shall contain fewer members than a quorum of the whole Arts Council.

Standing Committees

The following are the standing committees of the Arts Council.

- Community Relations: Assists with coordinating efforts related to public relations and community outreach on behalf of the Arts Council and its programs.
- Gallery: Assists with programming the Mercer Island Gallery at the Mercer Island Community & Event Center and the Greta Hackett Outdoor Sculpture Gallery.
- Literary: Assists with fostering appreciation of literature in the community by coordinating literary programs and collaborating with literary groups.
- Performing Arts: Assists with coordinating music, theater, and other performing arts programs.
- Public Art: Assists with stewarding Mercer Island’s public art collection.
- Special Projects: Assists with coordinating special programs and projects as they arise.

Detailed descriptions for standing committees are provided in the Arts Council Organization Manual.

Selection of Committee Chairs and Members

At the December meeting, staff will distribute Committee Interest Forms to board members. Members will return the forms to the Chair-elect. The Chair-elect, Vice Chair-elect, and staff liaisons will determine committee chair and member appointments and announce them at the January meeting. Committee chairs and members assume duties for one year beginning with the regular January meeting.

ARTICLE IV - OPERATIONS

1. MEETINGS

Regular & Special Meetings

Regular meetings of the Arts Council convene at 6:30 pm on the second Wednesday of each month at the Mercer Island Community & Event Center. Special meetings may be called by the Arts Council Chair by giving at least 24 hours advance notice to members and the City's paper of record in accordance with the Open Public Meetings Act. The notice must specify the time and place of the special meeting and the business to be transacted at the special meeting.

Commented [SB3]: DC and PC allow for Vice Chair, staff, or mayor to call special meetings in Chair's absence. Thoughts?

Officer Meetings

The Chair, Vice Chair, and staff liaisons may meet at least one week in advance of the regular Arts Council meeting to determine the meeting agenda.

2. ATTENDANCE

Each board member should strive to attend all Arts Council meetings, to read materials beforehand, and to participate fully. Except in instances of sudden illness or other unforeseen hardship, members should advise the staff and the Chair/Vice Chair of their intended absence before 4:30 p.m. on the day prior to the regular meeting. Excused absences will be noted for the record at the beginning of the meeting.

Commented [SB4]: Any additional comment or concern about this section?

A board member shall forfeit his/her position by failing to attend three (3) consecutive regular meetings of the Arts Council without being excused by the Chair.

3. QUORUM

A quorum consists of a simple majority of the appointed members of the Arts Council. No formal action of the Arts Council may be taken at any meeting where a quorum is not present. If a quorum is not reached at the start of a meeting, the Chair may choose to excuse the meeting.

4. ORDER OF BUSINESS

The Chair may adjust or amend the order of business as needed. The Arts Council's regular meetings normally use the following format:

- Call to Order

- Appearances
- Approval of Minutes
- Budget Report
- Agenda Items
- Other Business
- Adjourn

The Chair shall conduct meetings in an open, fair, and transparent manner. In the event of a procedural question, the Chair will refer to Robert’s Rules of Order for guidance.

5. ORDER OF BUSINESS

The Mercer Island city manager shall appoint a staff liaison to provide support services for the Arts Council. Staff support shall include, but not be limited to, assistance with the development of work plans and schedules, guidelines and procedures, correspondence, and agenda preparation and distribution.

Staff is also responsible for distributing all meeting notices and cancellations to the public as well as generating and updating the website calendar for upcoming Arts Council meetings.

ARTICLE V – CONFLICT OF INTEREST

If an actual or perceived conflict of interest exists that affects the work of the Arts Council, it is each board member's responsibility to openly describe the issue and refrain from any subsequent board participation, deliberation, or voting on the subject.

ARTICLE VI – PUBLIC REPRESENTATION AND STATEMENTS FROM THE BOARD

Any member of the board has a right to express personal views and opinions. However, statements representing the views or recommendations of the Arts Council must be authorized by a majority or consensus of the board. Consultation with staff on messaging is required.

Commented [SB5]: Added based on previous comment from Candace Chuck

ARTICLE VII – RESIGNATIONS

In an event that an Arts Council member wishes to vacate his/her term early, resignation should be tendered in writing to the Mayor and Deputy Mayor. Existing Arts Council members, staff liaisons, and the City Clerk will then recruit for a new member to fill the vacancy through Mercer Island’s established board/commission vacancy process.

ARTICLE VIII – RECOMMENDATIONS OF THE BOARD

The goal of the Arts Council is to provide recommendations to the City Council. When a consensus cannot be reached, a majority vote is taken. Minority positions may be conveyed as well. To document the actions taken by the Arts Council, staff will prepare a written statement or memorandum, including the facts, findings, and rationale for the final recommendations. The Chair in cooperation with the staff liaisons will present the recommendations to the City Council on behalf of the Arts Council.

ARTICLE IX – REVIEW OF BYLAWS

The Arts Council shall review bylaws annually at the Arts Council meeting in July. Proposed bylaw amendments must be approved by a majority of the Arts Council.

Commented [EV6]: Should we include a notice requirement?

Commented [SB7R6]: Don't think it's necessary

ARTICLE X: CODE OF CONDUCT

The Arts Council developed the following “group norms” to define the expectations for conduct by board members and the interaction among members. These are intended to be simple, self-explanatory, and self-enforced. The Chair is empowered to remind members as the need arises to employ these norms.

- Everyone contributes.
- Foster a collaborative environment.
- Hold each other accountable.
- Get to know each other and the community.
- Be transparent and accessible.

Date Approved: _____

Arts Council Chair: _____

Rev.	Description	Date	By
-	Initial Release - Permitting	12Aug2019	DG

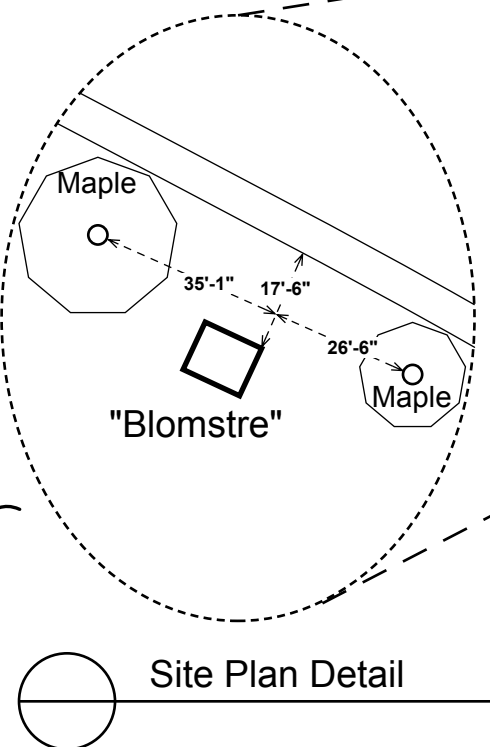
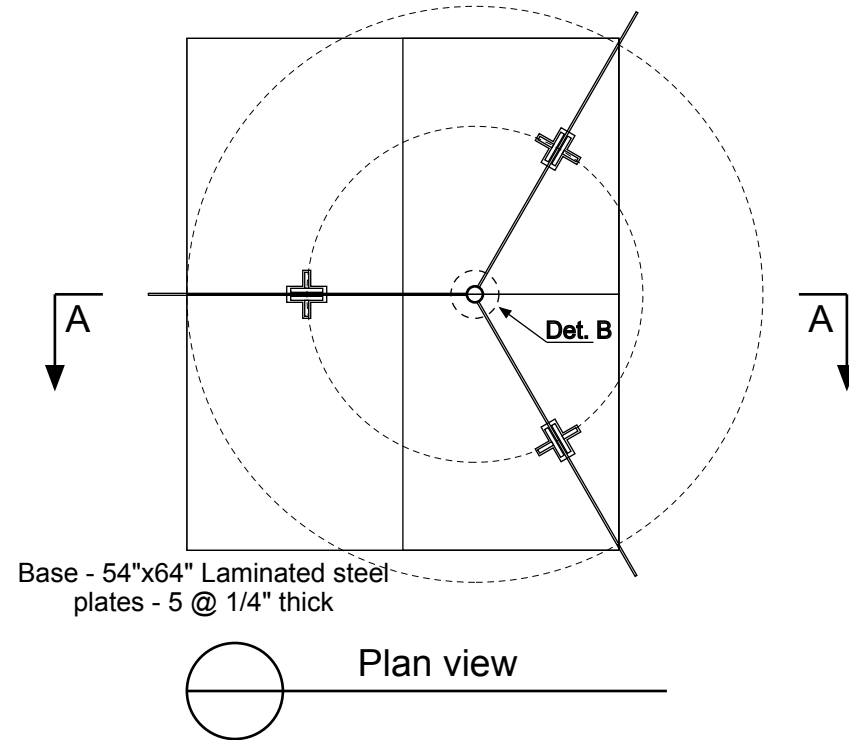
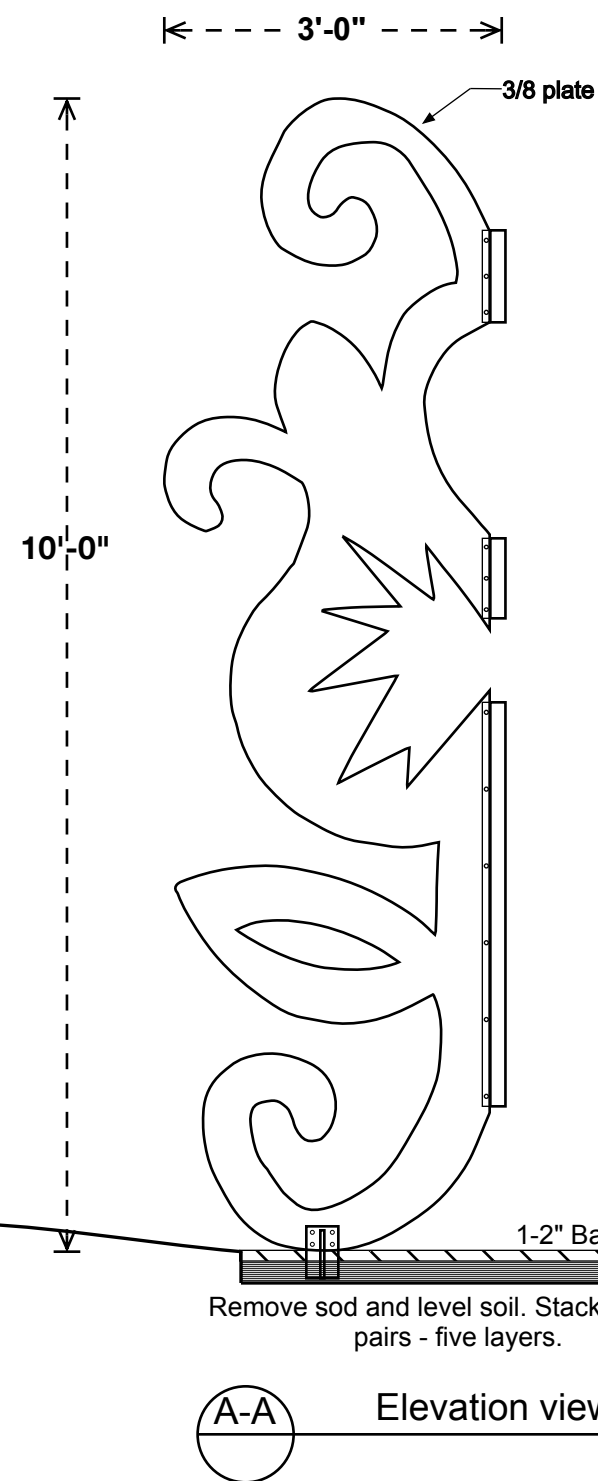

Lateral, Wind & Seismic:
 Wind: Assume worst case of 10 psf (ASCE 6.1.4.1) and full area 60 sq. ft. subject to load. Effective moment arm = 36" (min). Base weight (min) = 1,200 lbs. Actual 1,275+ lbs.
 Seismic & Lateral: Checked for seismic stability, but floating base plate results in no overturning moment. See seismic engineering report addendum.

Stamp	Title		Blomstre		Date		Sht	
	Lisa Hankes		Mercer Island WA		12Aug2019		1/1	
		G2 Engineers PLLC		Drawing No.		Site-01		
		Seattle WA		Scale		NTS		
Approved	Checked	Drawn	Scale	Date	Drawing No.	Sht		
DG			NTS	12Aug2019	Site-01	1/1		